

50x50x15mm

Model B

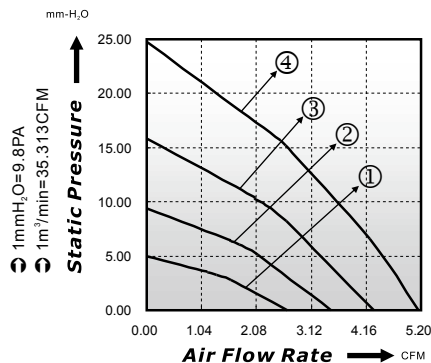

P-Q Curve (At Rated Voltage)



Dimensions Drawing

Unit: (mm)

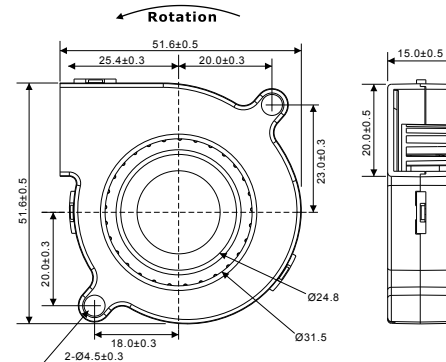

Model No	Bearing (*)	Rated Voltage (VDC)	Rated Current (A)	Power Consumption (Watts)	Speed (rpm)	Air Flow (CFM)	Static Pressure (mmH ₂ O)	Noise (dBA)	Curve
EBD05015-12L*	○ ● ⊖	12	0.15	1.80	3500	2.66	4.99	28.5	1
EBD05015-12M*	○ ● ⊖	12	0.20	2.40	4500	3.49	9.41	36.1	2
EBD05015-12H*	○ ● ⊖	12	0.30	3.60	5500	4.31	15.80	41.9	3
EBD05015-12HH*	○ ● ⊖	12	0.40	4.80	6500	5.16	24.80	47.5	4

* Bearing Type: ○ Sleeve ● Two Ball ⊖ Hydro-Dynamic